

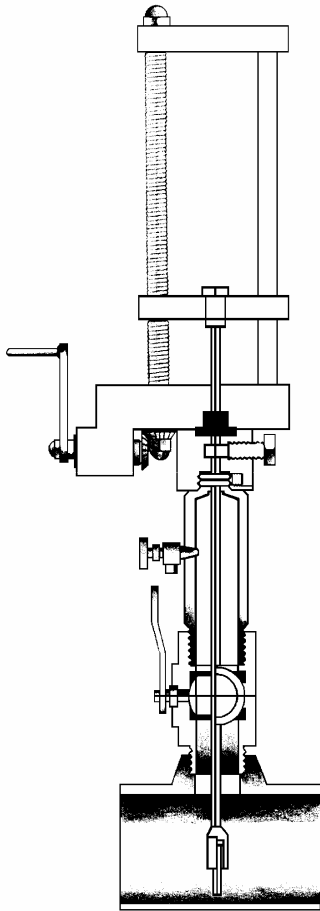

The Accurate Retractable Corrosion Coupon Holder!



The Easy One!

A unique patented system for monitoring internal corrosion where shutdown is impractical.

Field proven in pipelines, oil and gas production, waterfloods, refineries and other applications where retractable systems are required.

U.S. PATENT# 4,697,465

**Michael Anders and Patrick J. Anders
Accurate Corrosion Monitoring Company
P.O. Box 8509 • Longview, Texas • 75607
1-800-227-6183 * 903-757-7457 * Fax 903-236-3120
On the Internet at www.acmc-corrosion.com**

**© 2009 ACCURATE CORROSION MONITORING CO. LLC
ALL RIGHTS RESERVED**

Quality Assured

Accurated Corrosion Monitoring Company has been supplying retractable quills, spray nozzles, pneumatic atomizers, corrosion coupon holders and related equipment to the pipeline, oil and gas production, and refining industry for over 25 years. In addition, ACCMC offers the ability to design and manufacture custom equipment for special application needs.

When you use Accurate Retractable Systems you can be assured that you have equipment that has the following features and benefits!

- 1) All retractable systems are manufactured according to ANSI B31.3 Standards.
- 2) Each unit is machined from 316SS stock. It is not assembled from standard pipe fittings or off the shelf hardware items.
- 3) All 316SS used in the manufacturing is NACE MR0175-2003 Standards.
- 4) No 316SS is used that has a Rockwell C Hardness of greater than 22.
- 5) Each unit is available in most alloys.
- 6) Each unit is manufactured in accordance with ISO-9000 Requirements.
- 7) Each unit is hydrotested before shipping.
- 8) The Accurate Retractable Systems are of a Patented design.
(U.S.Patent 4,697,465)
- 9) Each unit has a permanent mechanical stop as a safety feature.
- 10) Each unit is designed to last for years with little maintenance.
- 11) Safety is a feature that is designed into every unit.

MANUFACTURED BY:

**ACCURATE TOOL COMPANY
KILGORE, TEXAS**

Special Items

These items normally do not fit into a standard category. Special items include fixed hex plug coupon holders, Acme Access Fittings Adapters, all thread spray nozzles, and any number of custom designed products. APMC can design and have manufactured almost any specialized retractable equipment systems.

Call our offices for more information on any specialized design item needs.

Items Include:

Fixed Hex Plug Coupon Holders

Fixed Injection Quills

Fixed Atomizers

All Thread Spray Nozzles

Fixed Flange Coupon Holders

Fixed Flange Injection quills

Fixed Flange Atomizers

***** alloys: = 316ss, Carbon Steel, Hastelloy C-276**

ACCURATE CORROSION MONITORING COMPANY

(800) 227-6183 • (903) 236-3120 FAX

ON THE INTERNET AT WWW.APMC-CORROSION.COM



FIXED HEX PLUGS CORROSION COUPON HOLDERS

ACMC offers fixed hex plug corrosion coupon holders for systems that can be depressurized. Fixed hex plug coupon holders are offered in all flanged (to 2-1/16" API 10000) or threaded (to 2" NPT) connections and can accommodate rod, multi-rod, flat, and disk coupons. Fixed hex plugs coupon holders are available in most alloys.

FIXED HEX PLUGS CORROSION COUPON HOLDERS



MULTIPLE ROD TYPE HIGH VELOCITY FLAT STANDARD ROD STANDARD

ACCURATE CORROSION MONITORING COMPANY

(800) 227-6183 • (903) 236-3120 FAX

ON THE INTERNET AT WWW.ACMC-CORROSION.COM



MODEL FMM50-ALT

RETRACTABLE SPRAY NOZZLE

Maximum Operating Pressure: 10000 PSI
(limited by flange rating)

Maximum Operating Temperature: 1000 F.

Method Of Operation: All Thread Safety
Clamp System

Maximum Insertion Length: 48 Inches

Insertion Rod Diameter: Standard 3/8" OD

Size Options: 1/2" NPT thru 2" NPT

Seals: Grafoil Seals

Material Construction: 316 S.S. complies with NACE standard MR-0175/2003. Suitable for H₂S service. Other metals available on request.

The Model FMM50-ALT is compact, sturdy, and lightweight. No special Acme access fittings, heavy service valve or bulky retrieval tool is required. Mount on existing valves of 1/2" NPT thru 2" NPT. Special Acme thread adapters are available to convert Acme access fittings to valve locations. These valve locations can then accommodate Accurate Retractable Spray Nozzles. The FMM50-ALT weighs less than 20 pounds when used with insertion lengths to 48".

MODEL FMM50-ALT ALL THREAD SPRAY NOZZLE

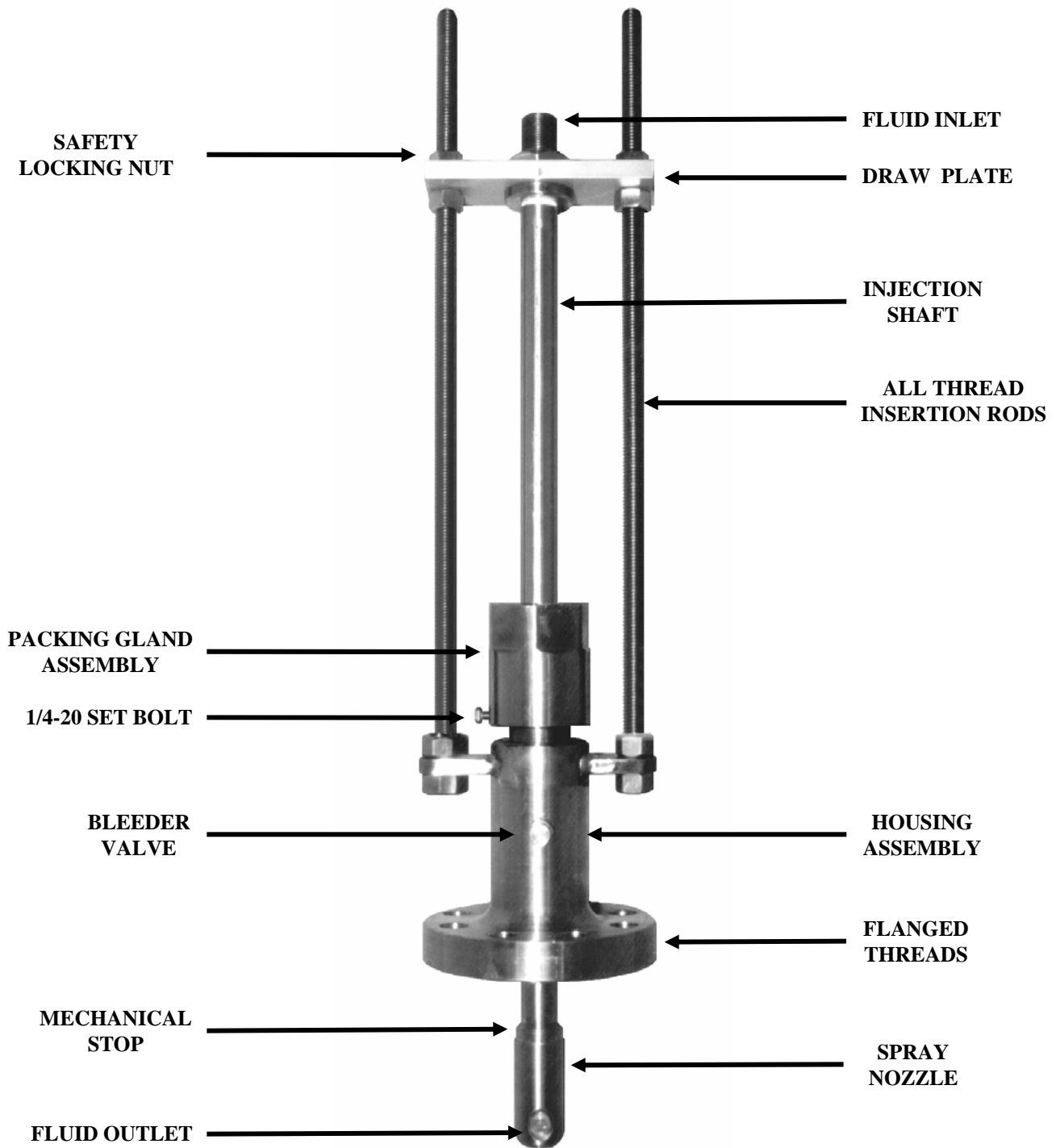

ACCURATE CORROSION MONITORING COMPANY

(800) 227-6183 • (903) 236-3120 FAX

ON THE INTERNET AT WWW.ACMC-CORROSION.COM



Ordering Information

How to Reach A.C.M.C.

Telephone 800-227 6183
903-757-7457

Fax 903-236-3120

Shipping Address A.C.M.C.
1630 E. Whaley St.
Longview, Texas
75601

Mailing Address A.C.M.C.
P.O. Box 8509
Longview, Texas
75607

On The Internet WWW.ACMC-CORROSION.COM
E-Mail Address SALES@ACMC-CORROSION.COM

ACCURATE CORROSION MONITORING COMPANY

(800) 227-6183 • (903) 236-3120 FAX

ON THE INTERNET AT WWW.ACMC-CORROSION.COM

